

F.I.A. Recognition No. **1434** . . .
 Group . . . **II Touring**

FEDERATION INTERNATIONALE DE L'AUTOMOBILE

Form of recognition in accordance with
 Appendix J to the International Sporting Code.

Manufacturer . Ford Motor Company Cylinder-capacity . 4740 cm³ 289 in³
 Serial No. of chassis . 6-100001 Model . 1966 Mustang Hardtop
 engine Manufacturer . Ford
 Recognition is valid from . **May 1, 1966** Manufacturer . Ford
 List . **14-4**

The manufacturing of the model described in this recognition form was started on
 . . . **Sept 1**, 1965 and the minimum production of . . . **2000** identical cars
 in accordance with the specifications of this form was reached on . . . **Nov. 1**, . . . 1965.



The vehicle described in this form has been subject to the following amendments:

<u>Variants</u>				<u>Normal evolution of the type</u>			
on.	19. .	rec.No	List	on	19. .	rec. No	List
on.	19. .	rec.No	List	on	19. .	rec. No	List
on.	19. .	rec.No	List	on	19. .	rec. No	List
on.	19. .	rec.No	List	on	19. .	rec. No	List
on.	19. .	rec.No	List	on	19. .	rec. No	List

Stamp and signature of the
 National Sporting Authority

Stamp and signature of the F.I.A.

G. W. M. Fleming
G. W. M. FLEMING
 EXECUTIVE DIRECTOR
 ACCUSO FIA, INC.
 433 MAIN STREET
 STAMFORD, CONN. 06901

Make

Model

F.I.A. Rec. No. 1434

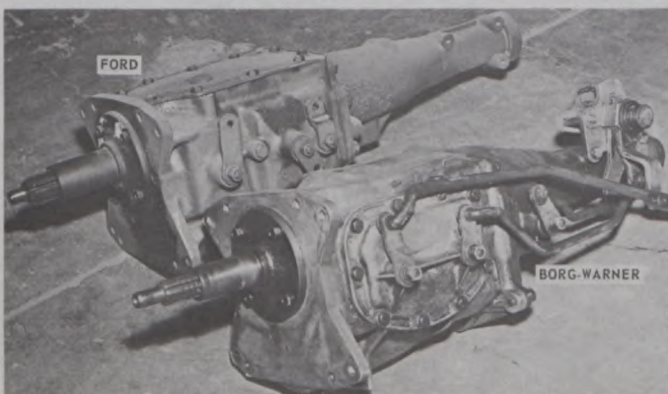
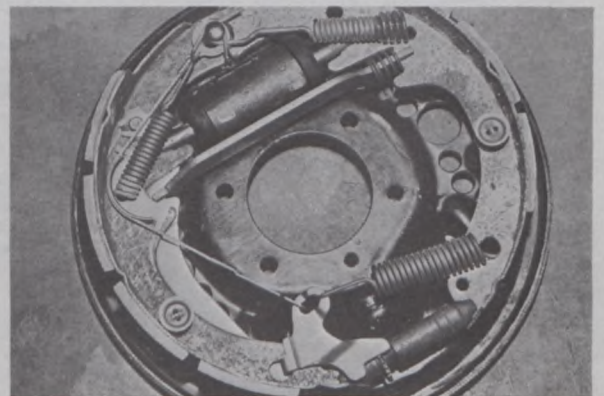
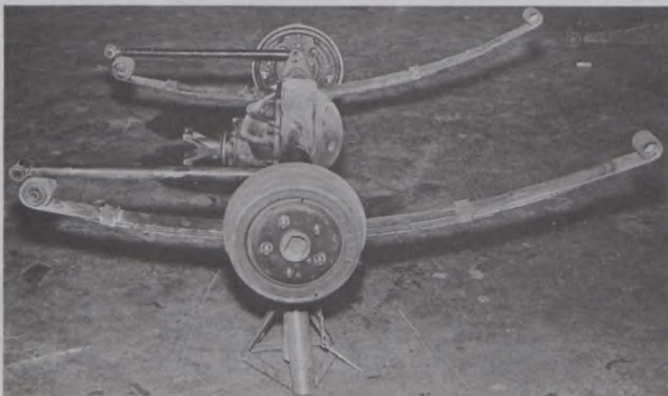
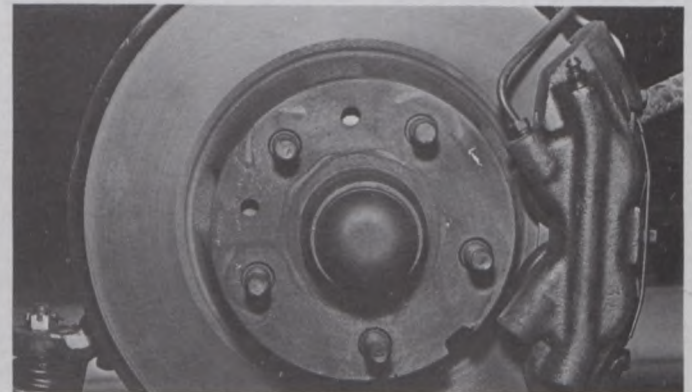
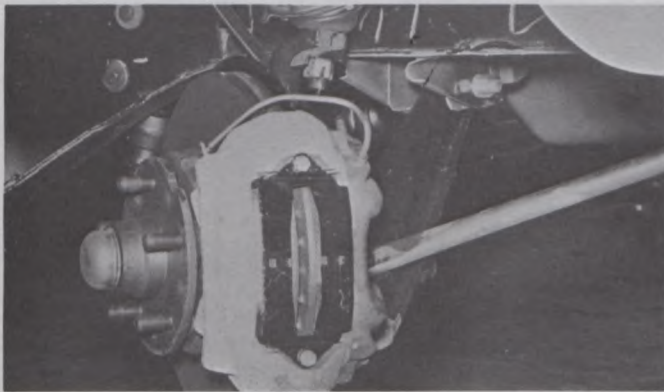
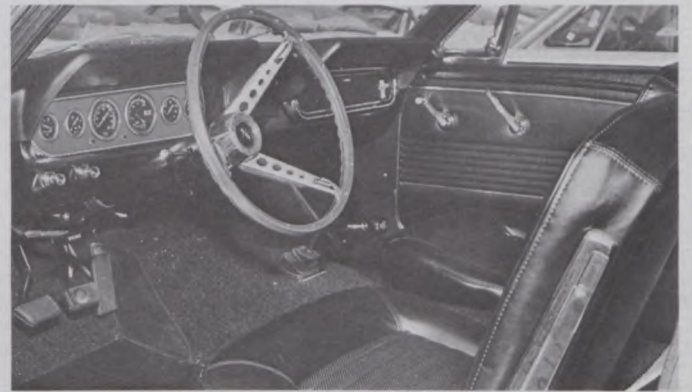

Make

Model

F.I.A. Rec. No. 1434

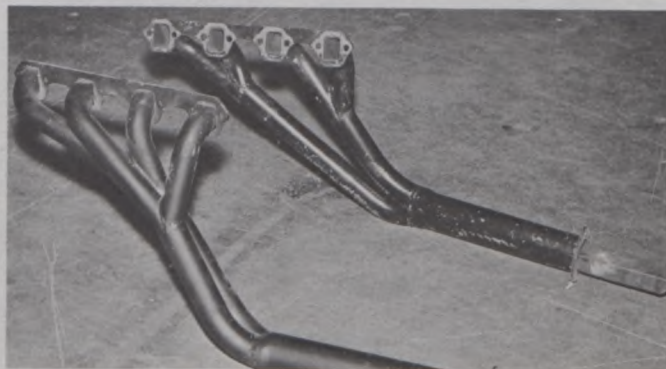
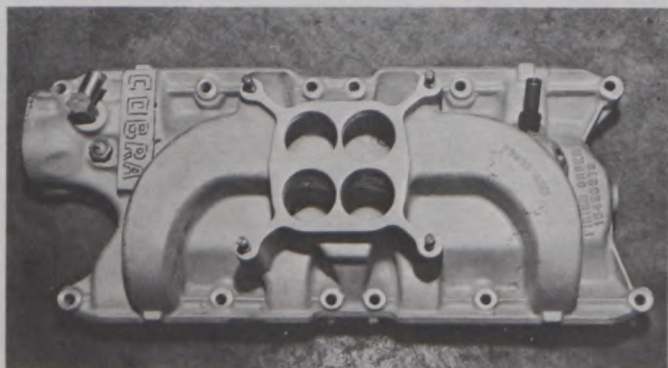
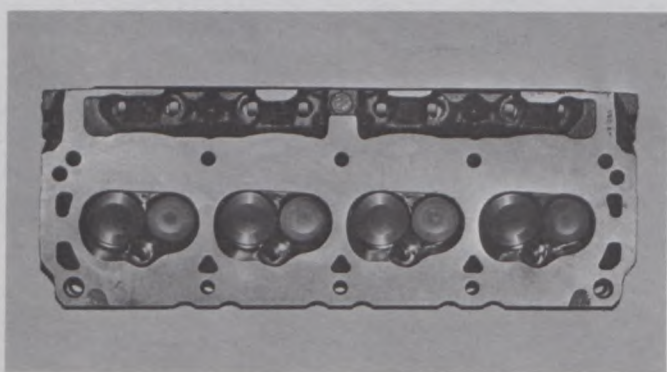
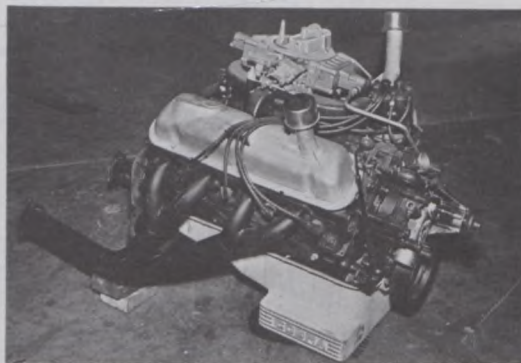
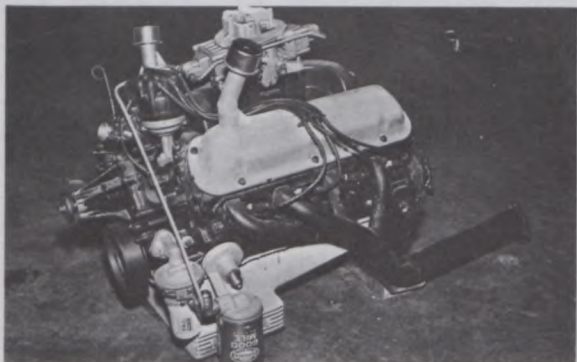

Make

Model

F.I.A.Rec.No. 1434

Drawing inlet manifold ports, side of cylinder-head. Indicate scale or dimensions and manufacturing tolerance.

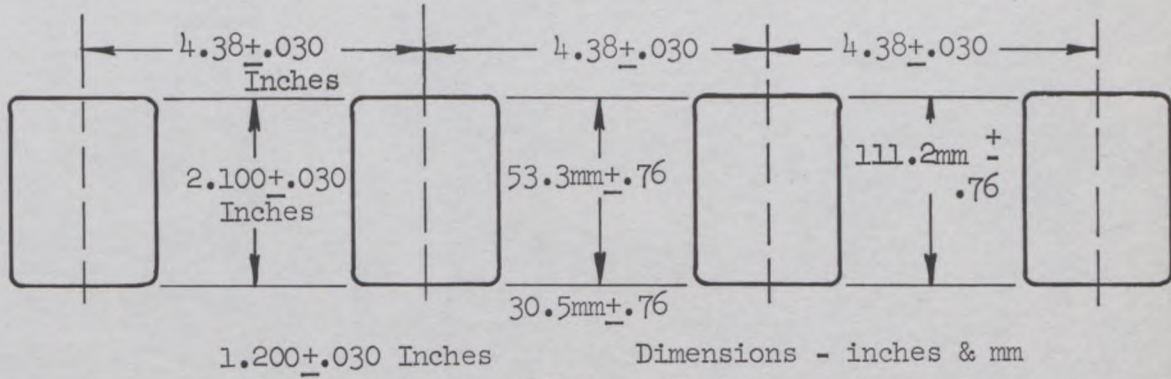

Drawing of entrance to inlet port of cylinder-head. Indicate scale or dimensions and manufacturing tolerance.

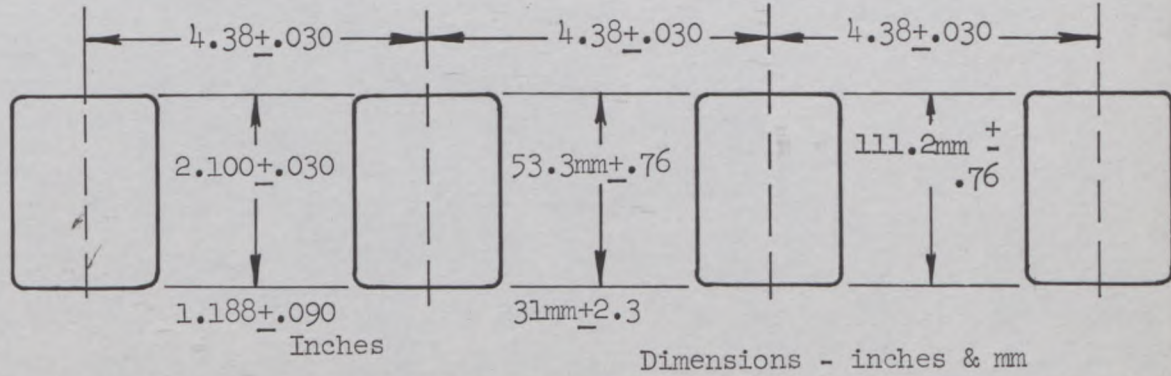

Drawing exhaust manifold ports, side of cylinder-head. Indicate scale or dimensions and manufacturing tolerance.

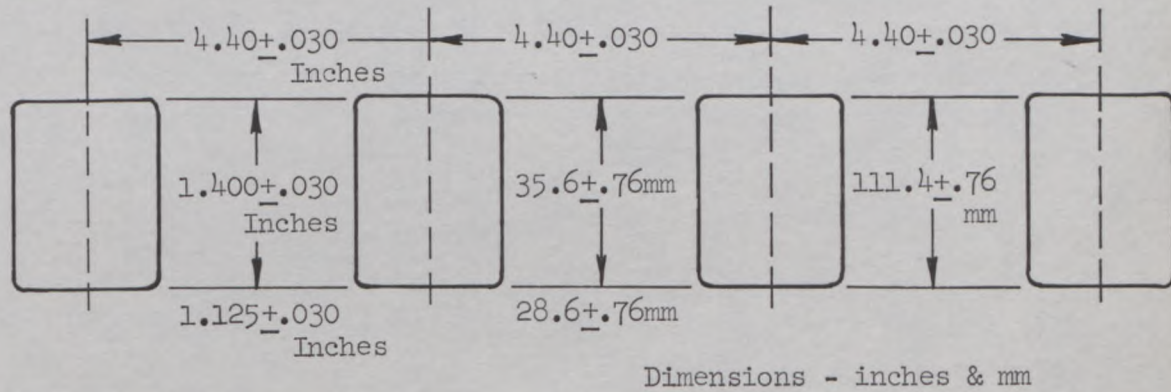

Drawing of exit to exhaust port of cylinderhead. Indicate scale or dimensions and manufacturing tolerance.

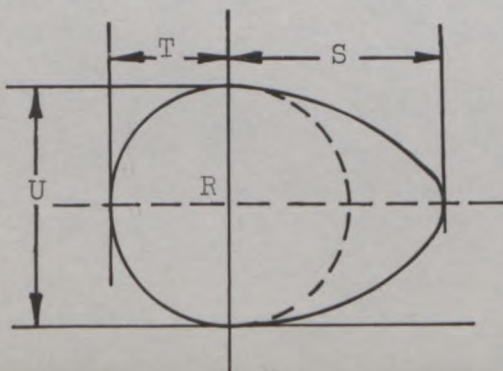
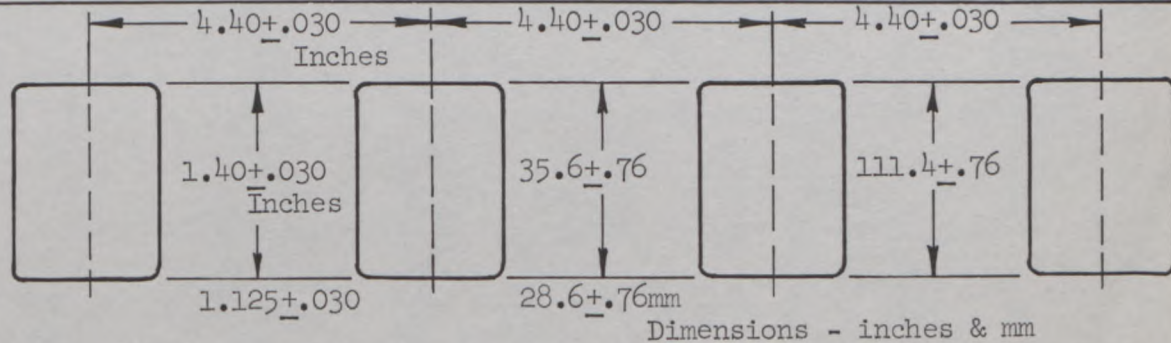

R = centre of camshaft.

Inlet cam

S =	mm	inches
T =	mm	inches
U =	mm	inches

Exhaust cam

S =	mm	inches
T =	mm	inches
U =	mm	inches

Make

Model

F.I.A.Rec.No. 1434

IMPORTANT - the underlined items must be stated in two measuring systems, one of which must be the metric system. See conversion table hereafter.

CAPACITIES AND DIMENSIONS

- 1. Wheelbase 2743 mm 108 inches
- 2. Front track ~~1400 x 1514~~ mm ~~58.6 x 59.6~~ inches*
- 3. Rear track ~~1400 x 1514~~ mm ~~58.6 x 59.6~~ inches*
- 4. Overall length of the car 461.3cm 181 inches
- 5. Overall width of the car 173.2 cm 68.2 inches
- 6. Overall height of the car 130.8cm 51.6 inches
- 7. Capacity of fuel tank (reserve included) 140 or 129 litres
37 or 34 Gallon US Gallon Imp.
- 8. Seating Capacity Four (4)
- 9. Weight, total weight of the car with normal equipment, water, oil and spare wheel but without fuel nor repair tools:
1182 ~~1190~~ kg 2606 ~~2603~~ lbs cwt

SEE CORRECTION SHEET, PAGE 11

*) Differences in track caused by the use of other wheels with different rim widths must be stated when recognition is requested for the wheels concerned. Specify ground clearance in relation to the track and give drawing of two easily recognizable points at front and rear at which measurements are taken. These ground clearance dimensions are only for information when checking the track and can in no way affect the eligibility of the car.

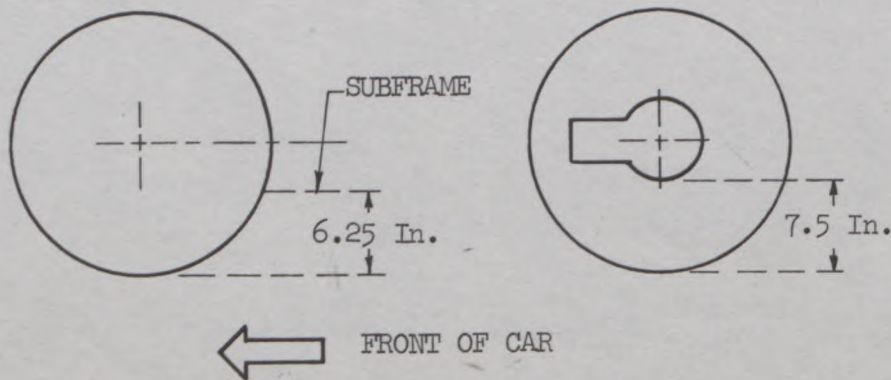

CONVERSION TABLE

1 inch/pouce	- 2.54	cm	1 quart US	- 0.9464	ltrs
1 foot/pied	- 30.4794	cm	1 pint (pt)	- 0.568	ltrs
1 square inch/pouce carre	- 6.452	cm ²	1 gallon Imp.	- 4.546	ltrs
1 cubic inch/pouce cube	- 16.387	cm ³	1 gallon US	- 3.785	ltrs
1 pound/livre (lb)	- 453.593	gr.	1 hundred weight (cwt)	- 50.802	kg

BRAKES (Photographs F and G)

90.	Method of operation	Hydraulic			
91.	Servo-assistance (if fitted), type				
92.	Number of hydraulic master cylinders	(1) one			
		FRONT		REAR	
93.	Number of cylinders per wheel		4		1
94.	Bore of wheel cylinder(s)	41.3 mm	1.63 in.	23 mm	in.
	Drum Brakes				
95.	Inside diameter	mm	in.	254 mm	in.
96.	Length of brake linings	mm	in.	475 mm	in.
97.	Width of brake linings	mm	in.	63.5 mm	in.
98.	Number of shoes per brake		2		
99.	Total area per brake	mm ²	sq.in.	30,300 mm ²	sq.in.
	Disc brakes				
100.	Outside diameter	287 mm	in.	mm	in.
101.	Thickness of disc	20 mm	in.	mm	in.
102.	Length of brake linings	123 mm	in.	mm	in.
103.	Width of brake linings	46 mm	in.	mm	in.
104.	Number of pads per brake		2		
105.	Total area per brake	11,316 mm ²	sq.in.	mm ²	sq.in.

ENGINE (Photograph J and K)

130.	Cycle	Four (4)			
131.	Number of cylinders	Eight (8)			
132.	Cylinder arrangement	V8			
133.	Bore	101.73 mm	4.005 in.		
134.	Stroke	72.9 mm	2.87 in.		
135.	Capacity per cylinder		591 cm ³	36.13 cu.in.	
136.	Total cylinder-capacity		4740 cm ³	289 cu.in.	
137.	Material(s) of cylinder block	Cast Iron			
138.	Material(s) of sleeves (if fitted)	None			
139.	Cylinder-head, material(s)	Cast Iron	Number fitted	2	
140.	Number of inlet ports	Eight (8) - 4 per head			
141.	Number of exhaust ports	Eight (8) - 4 per head			
142.	Compression ratio				
143.	Volume of one combustion chamber		cm ³	cu.in.	
144.	Piston, material				
145.	Number of rings				
146.	Distance from gudgeon pin centre line to highest point of piston crown	mm	inches		
147.	Crankshaft:	moulded/stamped			
148.	Type of crankshaft:	integral/			
149.	Number of crankshaft main bearings	Five (5)			
150.	Material of bearing cap	Cast Steel			
151.	System of lubrication:	Oil in Sump			
152.	Capacity, lubricant	8.04 lts	pts	8.5	quarts US
153.	Oil cooler: yes - no				
154.	Method of engine cooling	Water			
155.	Capacity of cooling system	17.1 ltrs	pts	18	quarts US
156.	Cooling fan (if fitted) dia.	cm.	inches		
157.	Number of blades of cooling fan				

Make

Model

F.I.A.Rec.No. 1434

INJECTION (if fitted)

- 220. Make of pump
- 221. Number of plungers
- 222. Model of type of pump
- 223. Total number of injectors
- 224. Location of injectors
- 225. Minimum diameter of inlet pipe mm in.

ENGINE ACCESSORIES

- 230. Fuel pump: mechanical and/or electric
- 231. No. fitted one mechanical and one electric
- 232. Type of ignition system Battery and coil
- 233. No. of distributors One (1)
- 234. No. of ignition coils One (1)
- 235. No. of spark plugs per cylinder One (1)
- 236. Alternator, number fitted One (1)
- 237. Method of drive Belt
- 238. Voltage of alternator 12.8 volts
- 239. Battery, number One (1)
- 240. Location Rear of Car
- 241. Voltage of battery 12 volts

ENGINE AND CAR PERFORMANCES (as declared by manufacturer in catalogue)

- 250. Max. engine output (type of horsepower:)at rpm
- 251. Maximum rpm output at that figure
- 252. Maximum torque at rpm
- 253. Maximum speed of the car km/hour miles/hour

DRIVE TRAIN

CLUTCH

- 260. Type of clutch Dry Plate
- 261. No. of plates One (1)
- 262. Dia. of clutch plates 26.7 cm in.
- 263. Dia. of linings, inside cm in.
- outside 26.7 cm in.
- 264. Method of operating clutch Mechanical

GEAR BOX (Photograph H)

- 270. Manual type, make Borg Warner or Ford
- 271. No. of gear-box ratios forward Four (4)
- 272. Synchronized forward ratios Four (4)
- 273. Location of gear-shift Floor
- 274. Automatic, make Ford Type: Torque Converter with planetary gears
- 275. No. of forward ratios Three (3)
- 276. Location of gear-shift Floor

BORG WARNER

FORD

277	Manual		Automatic		Alternative manual			
	Ratio	No teeth	Ratio	No teeth	Ratio	No teeth	Ratio	No teeth
1.	2.36:1	$\frac{26}{29} \frac{36}{17}$	2.46	Torque Converter Maximum Ratio At Stall 2.02:1	2.32	$\frac{23}{25} \frac{32}{15}$		
2.	1.62:1	$\frac{26}{29} \frac{29}{20}$	1.46		1.69	$\frac{23}{25} \frac{28}{18}$		
3.	1.20:1	$\frac{26}{29} \frac{27}{25}$	1.00		1.29	$\frac{23}{25} \frac{25}{21}$		
4.	1.00:1	Direct			1.0	Direct		
5.								
6.								
reverse	2.42:1		2.20		2.32			

- 278. Overdrive type
- 279. Forward gears on which overdrive can be selected
- 280. Overdrive ratio

FINAL DRIVE

- 290. Type of final drive Conventional, Semi-Floating, Straddle Mounted Pinion
- 291. Type of differential Locking - Ratchet Type
- 292. Type of limited slip differential Mechanical Locking
- 293. Final drive ratio 3.89 or 3.70 or 4.33 or 3.50
Number of teeth 35-9 or 37-10 or 39-9 or 35-10

IMPORTANT - The conformity of the car with the following items of the present recognition form is to be disregarded during the scrutineering, when the vehicle has been entered in group 2 (Touring cars) or 3

(Grand Touring cars): 41, 72, 80, 91, 142, 143, 144, 145, 146, 153, 156, 157, 160, 161, 162, 163, 164, 182, 184, 186, 187, 188, 189, 199, 201, 202, 203, 212, 215, 216, 222, 225, 230, 250, 251, 252, 253 and photographs I, M and N.

During the scrutineering of cars entered in group 4 (Sportscars) only the following items of the present recognition form are to be taken into consideration: 1, 2, 3, 9, 20, 21, 22, 23, 24, 25, 26, 70, 71, 78, 79, 90, 130, 131, 132, 133, 134, 135, 136, 137, 138, 139, 140, 141, 147, 148, 149, 150, 158, 159, 170, 171, 172, 173, 185, 200, 270, 271, 274, 275, 290, 291, 292 and photographs A, B, D, E, F, G, H, J, K, and O.

Optional equipment affecting preceding information. This to be stated together with reference number.

B7AZ 4209-C 4.11:1 Final Drive Ratio 37-9 teeth

Guard for Sump and Fuel Tank

6x15 inch Steel Wheels (153 mm X 381 mm) ~~TYPE X 148 X (58.6 X 15)~~

SEE CORRECTION SHEET, PAGE 11

7.5x15 inch Wheels (191 mm x 381 mm) ~~TYPE X 150 X (59.1 X 15)~~

F.I.A. Recognition No. 1434

Group. . .II Touring

Ford Motor Company --- 1966 Mustang Hardtop

CORRECTION SHEET

Track of vehicle as related to listed rim widths:

<u>Listed Rim Width</u>	<u>Front Track</u>	<u>Rear Track</u>
6½"	58.0"	57.4"
7 "	58.6"	58.0"
7½"	59.1"	58.5"
8 "	59.6"	59.0"

